



# MX1050XTS

## Hi-Power Blender with 64 oz. Stainless Steel Container



Hi-Power Electronic Keypad Blender with 64 oz. Stainless Steel Container



\*Made in USA with US and foreign parts.

### ELECTRICAL

Voltage: 120V

Frequency: 60Hz

Watts: 1560W

Amps: 12.5A

Plug Type: NEMA 5-15P

Cord Length: 6 feet



### MAIN FEATURES

- Heavy-duty, high-performance 3 1/2 peak HP motor with 2 speed selections is the strongest in its class. It powers through the toughest ice and frozen fruit mixtures in seconds.
- Super-high, 30,000+ RPM motor speed for the smoothest consistencies.
- Unbreakable, dishwasher-safe, 64 oz., stainless steel container has a cloverleaf jar design to create a high-power vortex, funneling food directly into the blade.
- High-grade, high-impact, stainless steel blade is user replaceable for easy servicing.
- User-replaceable, metal-on-metal, stainless steel coupling system for durability and reliability.
- Easily removable container cover with removable clear cap lets you add ingredients and reduce pressure during hot food blending.
- Optional sound enclosure easily retrofits to base for serious noise reduction.
- One-piece, dishwasher-safe, removable jar pad..
- Recommended for 75+ cycles per day.
- Limited Three-Year Motor Warranty and Two-Year Parts and Labor Warranty.

### SALES FEATURES

Get smooth, consistent results every time with the Waring® MX1050XTS. This heavy-duty, powerful 3½ peak HP blender teams up with our stainless steel jar/ blade assembly for maximum power and efficiency. It's ferocious enough for everything from smoothies and frozen drinks to thick spreads, desserts, dressings, and all types of food preparation. This workhorse features an easy-to-clean, electronic membrane keypad with HIGH, LOW, OFF and PULSE functions. Blend 75+ cycles per day. It's perfect for a busy bar, health facility, school, or coffee shop.



@waringcommercial

©2022 Waring Commercial  
314 Ella T. Grasso Avenue, Torrington, CT 06790  
Tel. 800-492-7464 • Fax 860-496-9008

waringcommercialproducts.com

MX1050XTS



# Hi-Power Electronic Keypad Blender with 64 oz. Stainless Steel Container MX1050XTS

## PARTS & ACCESSORIES

- |   |  |   |  |
|---|--|---|--|
|    | <b>CAC90</b><br>64 oz. Stainless Steel Container   |    | <b>CAC95-12</b><br>64 oz. Green Copolyester Container                      |
|    | <b>CAC93X</b><br>48 oz. Copolyester Container  |    | <b>CAC95-28</b><br>64 oz. Orange Copolyester Container                     |
|    | <b>CAC93X-03</b><br>48 oz. Yellow Copolyester Container  |    | <b>CAC116</b><br>Blending Assembly Kit and Retainer Ring Kit               |
|    | <b>CAC93X-06</b><br>48 oz. Blue Copolyester Container  |    | <b>CAC119</b><br>Retainer Ring Wrench                                      |
|    | <b>CAC93X-10</b><br>48 oz. Purple Copolyester Container  |    | <b>CAC158</b><br>Blending Assembly Kit                                     |
|   | <b>CAC93X-12</b><br>48 oz. Green Copolyester Container   |    | <b>CAC159</b><br>Retainer Ring Kit   |
|  | <b>CAC93X-28</b><br>48 oz. Orange Copolyester Container  |   | <b>CAC160</b><br>Drive Coupling  |
|  | <b>CAC95</b><br>The Raptor® – Aggressive, All-Purpose, Stackable, 64 oz., BPA-Free Copolyester Container |  | <b>CAC161</b><br>Drive Coupling Removal Tool                               |
|  | <b>CAC95-03</b><br>64 oz. Yellow Copolyester Container   |  | <b>CAC169</b><br>Spatula – Custom designed for use with MX Series Blenders |
|  | <b>CAC95-06</b><br>64 oz. Blue Copolyester Container   |  | <b>SE1000</b><br>Large Sound Enclosure                                     |
|  | <b>CAC95-10</b><br>64 oz. Purple Copolyester Container   |  | <b>SE500</b><br>Small Sound Enclosure                                      |

## DIMENSIONS

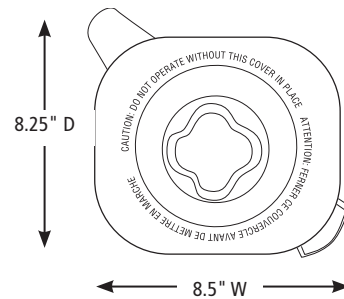
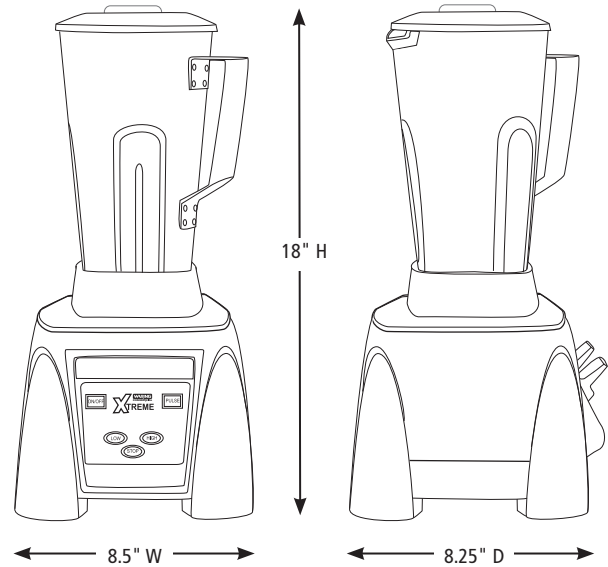

Out-of-Box Weight: 11.70 lb.

ORDERING INFORMATION	#STD. PKG.	GIFTBOX WEIGHT	CUBIC FEET	BOX DIMENSIONS D X W X H	UPC	CASE PKG.	MC WEIGHT	MC DIMENSIONS D X W X H	MBC
MX1050XTS– Hi-Power Electronic Keypad Blender with 64 oz. Stainless Steel Container	1	18.85 lb.	1.22	11.75" x 10.875" x 16.5"	040072006722	1	18.85 lb.	11.75" x 10.875" x 16.5"	10040072006729



@waringcommercial

©2022 Waring Commercial  
314 Ella T. Grasso Avenue, Torrington, CT 06790  
Tel. 800-492-7464 • Fax 860-496-9008

waringcommercialproducts.com

22WC084402 / REV 07/22